

1. Attach Ubiquiti radio to adapter and align larger, UNLOCKED indent with radio's RELEASE BUTTON. Slot in adapter and rotate to smaller, LOCKED indent. To remove radio, press RELEASE BUTTON and rotate adapter to UNLOCKED indent.

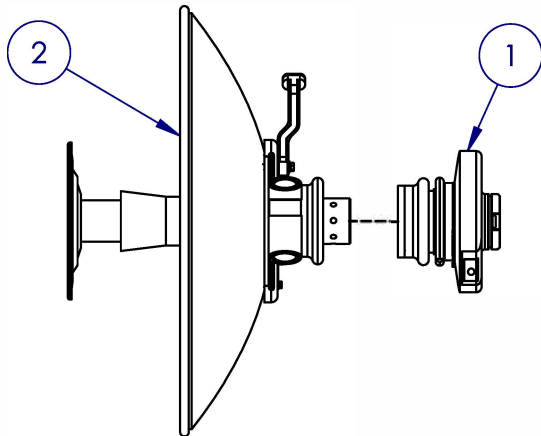

2. Align assembled radio adapter with feed assembly's input waveguide.

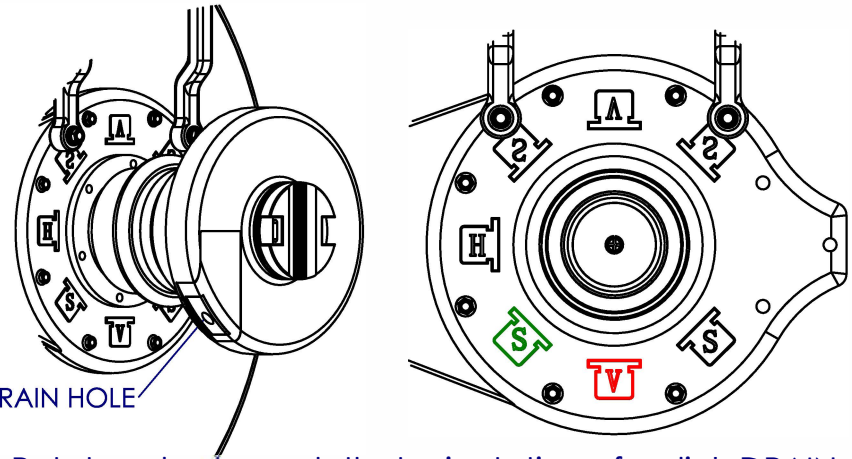

3. Rotate adapter such that orientation of radio's DRAIN HOLE is directed down. For Horizontal/Vertical polarization, align release button with antenna's bottom **V** indicator. For +/-45 Slant polarization, align release button with antenna's bottom left **S** indicator.

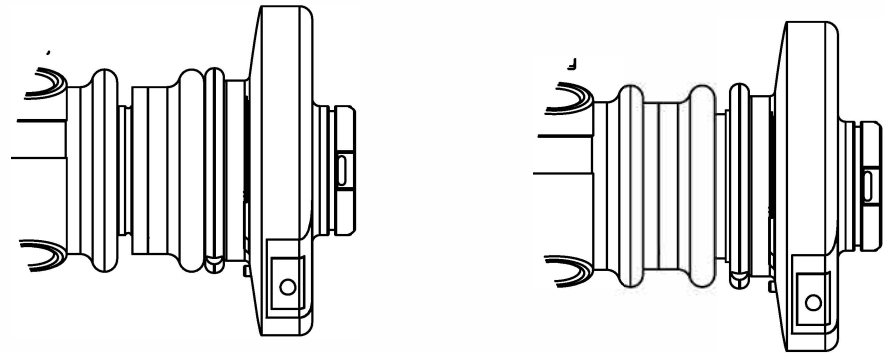

4. Pull back collar on Quick-Connect Waveguide Coupler and slide adapter over feed assembly. Release coupler.

NO.	DESCRIPTION	QTY
1	KP-5PDA-UIS5	1
2	KP-5PD-1 / KP-5PD-2	1